

Hydrotab

Powerful dynamic trimming, higher stability, better maneuvering

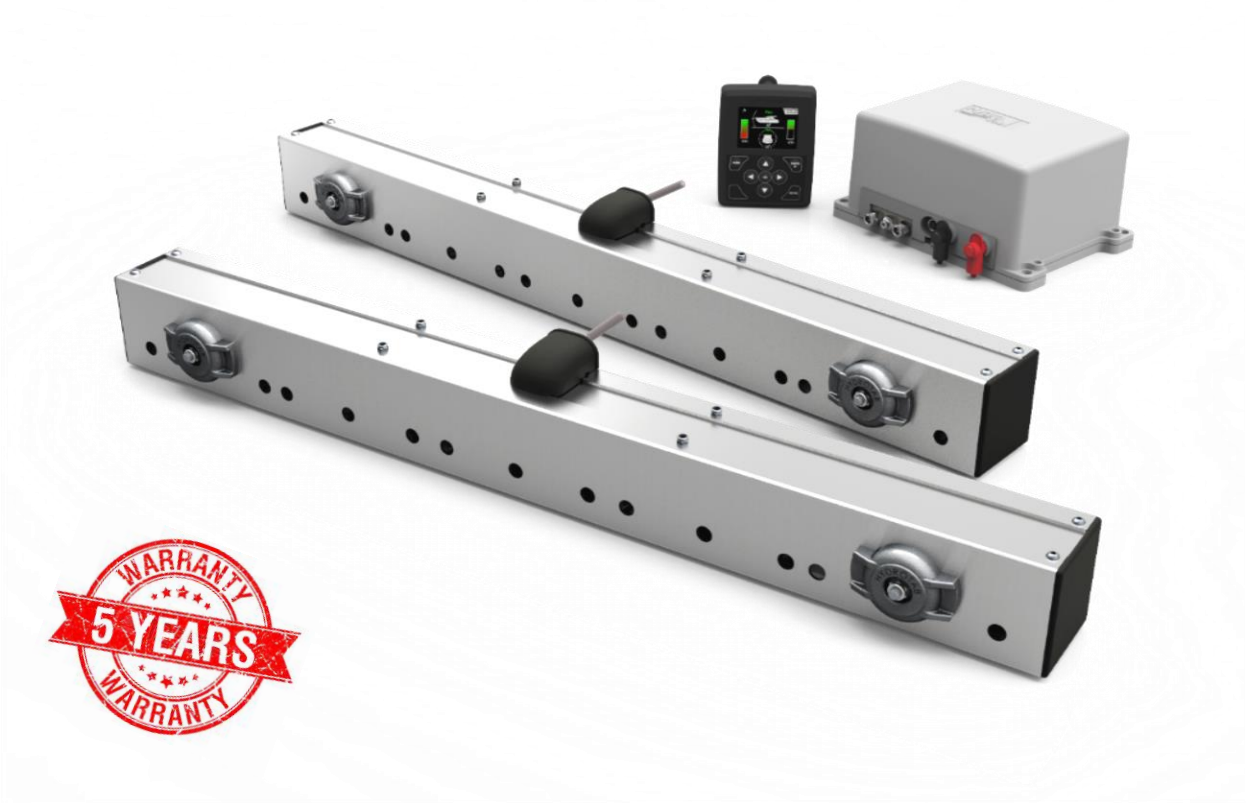

When you choose to install Hydrotab Interceptors feel confident that you have aboard a powerful and high performance dynamic trim system with the highest resilience in rough sea conditions and hard use. It is a supreme quality equipment made to outlast adversities and offer an excellent sea riding experience. Hydrotab Interceptors are covered with 5year Quality Warranty.



- **Powerful, effective, dynamic trim and stability control (pitch, roll, pitch&roll, steering assistance)**
- **33% more stability control due to increased sizing (stroke & length)**
- **Faster and easier planing, advanced steering consistency, fuel saving**
- **Enhance boat's stability, minimizes roll (list) and unpleasant "rocking"**
- **Increase feel of comfort and safety**
- **Manual or Full Auto Dynamic Control (NMEA2000) with very simple operation and easy to handle menu**
- **High resilience in rough sea conditions or hard use, and practically unaffected by barnacle, fouling, hits and bumps, low or high temperatures**
- **Very simple and minimal DIY installation with the least of space and time required. Simple Plug & Play NMEA2000 wiring.**
- **With remarkably long lifespan, Hydrotab Interceptors are covered with 5year Quality Warranty**
- **Low acquisition cost and near zero service and maintenance costs**

Why Hydrotab is a premium quality product?

Hydrotab Trim System blends together a number of features which makes it a top choice in marine market today. It performs a powerful dynamic trim control and enhances boat stability (Pitch, Pitch&Roll, Steering Assistance) providing a unique sea riding experience.

With a design based on an innovative pneumatic mechanism, Hydrotab Interceptors can bear up hard use and satisfy even the most demanding users. Free of sensitive parts (rotating parts, gears, shafts, servomotors, electronics, rams, pistons, sealing or other hydraulic parts), the innovative pneumatic mechanism is highly resilient in harsh sea conditions, hard use, hits and bumps, low or high temperatures, and practically is unaffected by barnacle and fouling. Hydrotab Interceptors are manufactured under strict specifications, with top quality Inox316 steel which makes them practically indestructible and endows them with a surprising long lifespan.

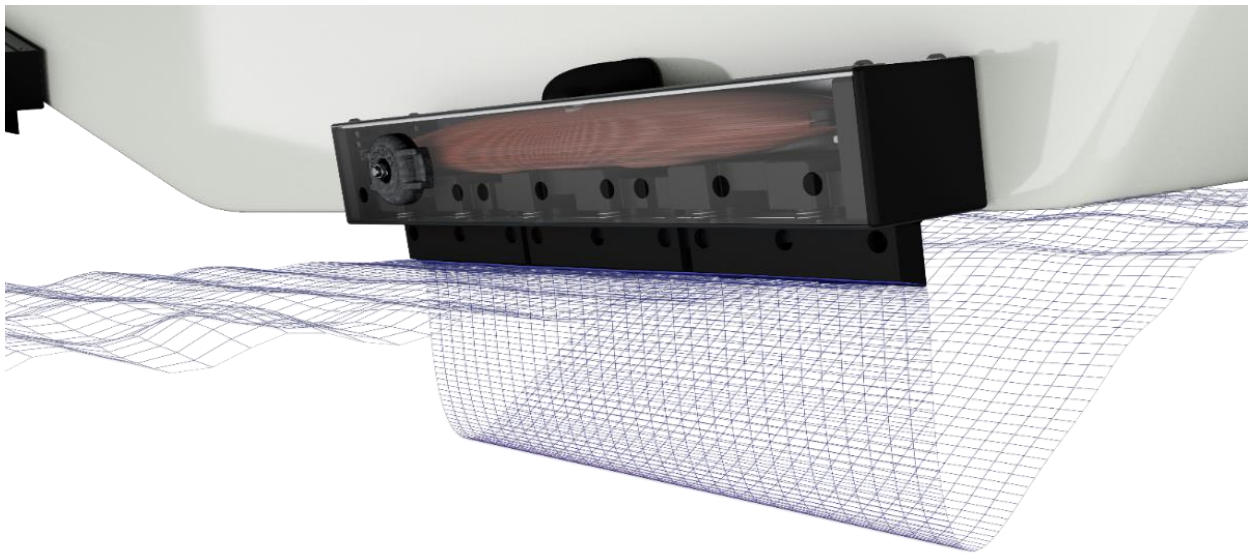

Can Hydrotabs trim better than ordinary trim tabs?

All who experienced a cruise using interceptors claims that performance, stability, and steering consistency was considerably increased comparing to the common trim tab plates driven by hydraulic/actuators/servomotors. Response of the boat is instant, maneuvering is more precise, installation and handling of trimming system is minimal and much simpler. Hydrotabs not only provide an excellent cruising experience, but offer at the same time a high quality and robust trimming equipment, with the highest resilience in harsh conditions and hard use.

Is Hydrotab interceptors appropriate for all kind of boats?

Hydrotab trim interceptors are appropriate for

- boats with cruising speed from 18knots or above
- displacement, semi-displacement or planing hulls
- boats of 15'-120' length
- propeller or jet propulsion, inboard or outboard engines
- RIB, polyester, wood, aluminum or steel hulls
- leisure, working, military or any special purpose boats
- mono or multihull vessels

Do I have options of control modes?

Hydrotab offers either traditional Manual or Full Automated (NMEA2000) dynamic control, however both options provide excellent power trimming and a friendly and easy to use operation.



+ **3DHC Manual control** is a 4button controller with led position indicators, simple commands (both up, both down, strb up/port down, strb down/port up) and basic automation options for auto-retracting and a pre-set memory.



+ **4DHC Full Auto** (NMEA2000, plug & play wiring) dynamic controller offers options among Manual control, Auto Pitch control, Auto Pitch&Roll control, as well as Steering Assistance mode. 4DHC control device has a 3.2" colored screen and with embedded GPS, Gyroscope and 3D accelerometer can stand alone or get connected to boat's NMEA network. This dynamic control system offers a unique experience of planing, steering consistency and control over the boat, as well as comfort and safety aboard.

Does Hydrotab have all the appropriate references?

Hydrotab Marine Engineering is an OEM manufacturer for exceptional luxurious yachts makers (Ferretti, Custom Line, Pershing, SeaLine, Marlow-Hunter, Horizon, Gulf Craft, Sundeck, etc). Hydrotab has also significant references for military, patrol and other special purpose vessels (Korean Marines, Singapore Coastguard, Greek Navy etc). Furthermore, Hydrotab counts hundreds of successful and long-life installations on different hulls of boats sailing all over the world in warm or freezing-cold waters and every kind of sea conditions.

Is Hydrotab easy to install?

Hydrotab is probably the easiest and simplest trimming product in terms of installation. It is offered in a DIY box and requires minimum space on transom and the least of odd job and wiring.



What exactly is the Hydrotab Quality Warranty?



As a proof of premium quality, Hydrotab Interceptors are covered with **5year Quality Warranty**. During the period of Warranty, all spare and replacement parts are free of charge.

In addition, all electric or electronic parts are covered with 2year warranty.

BT Series

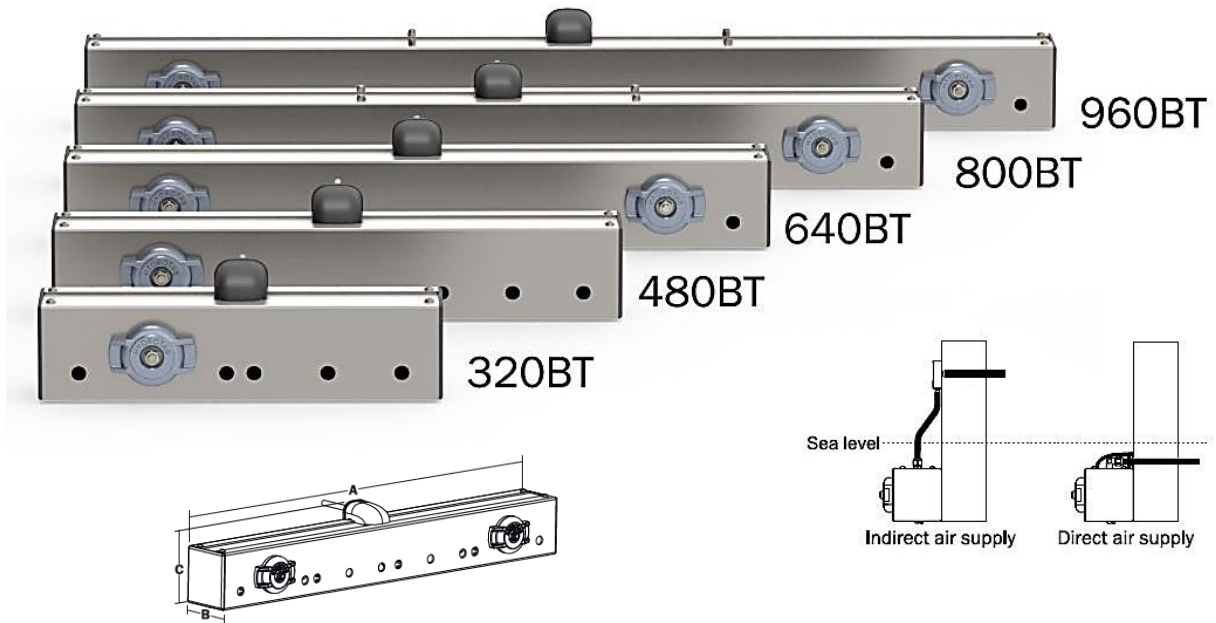

Model	Dimensions (mm)			Package Weight (kgrs) (Including Control device and installation parts)	Package Dimensions (mm)
	A	B	C		
320BT	370	89	115,5	18	Carton Box 720x320x290(h)
480BT	544	89	115,5	20	Carton Box 720x320x290(h)
640BT	700	89	115,5	26	Carton Box 720x320x290(h)
800BT	870	89	115,5	29	Carton Box 1040x320x290(h)
960BT	1030	89	115,5	37	Carton Box 1040x320x290(h)
1500BT	1540	89	115,5	53	Pallet 1600x280x550(h)
2000BT	2040	89	115,5	65	Pallet 2100x280x560(h)

Indicative Size	Boat Length LOA (feet)	Suggested model
The following table is indicative, and it differs depending on the boat type and displacement. It is always recommended to choose the biggest Hydrotab model that can be fitted on your boat.	15-22	320BT
	22-34	480BT
	32-42	640BT
	40-53	800BT
	50-70	960BT
	70-90	1500BT
	90-120	2000BT

*Can also be used combination of above models

FW Heavy Duty Series



Hydrotab FW series with blades made of inox316 stainless steel, offers the ability to develop custom shaped products with blade shapes according to V line of the transom.



Hydrotab installation drawing

Hydrotab installation is simple and requires minimum of odd jobs, as well as the least of time, space and material.

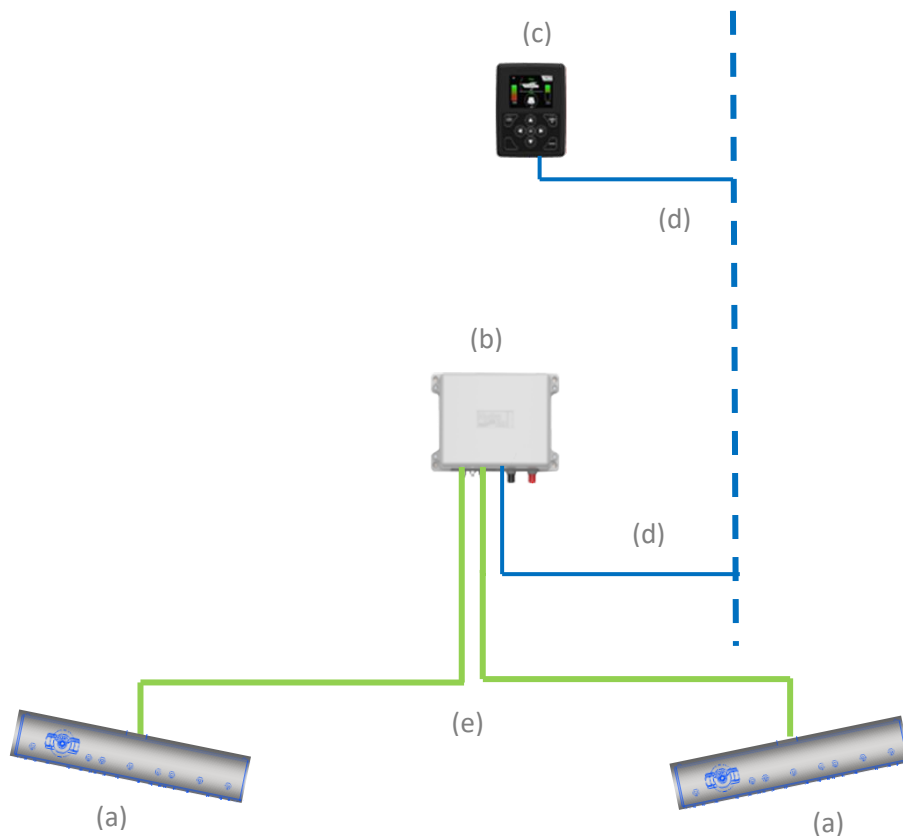

A regular Hydrotab set includes (a) Interceptors, (b) Air Unit, (c) Control Unit, (d) NMEA Connection Cables, and (e) Air Pipes.

3DHC manual Controller: Power Supply 12 or 24Volts DC,

4DHC Auto Controller: Power Supply 12 or 24Volts DC

Air Unit Power Supply: DC 12Volt (110Watts) or 24Volts (240Watts),

Air Unit Maximum Operating Pressure: 2,5bars



Hydrotab Marine Engineering
tel. +30 210 4836343
info@hydrotab.gr, www.hydrotab.gr